

TIPOLOGIA DELLE LANTERNE DISPONIBILI / TYPE OF AVAILABLE BELLHOUSINGS

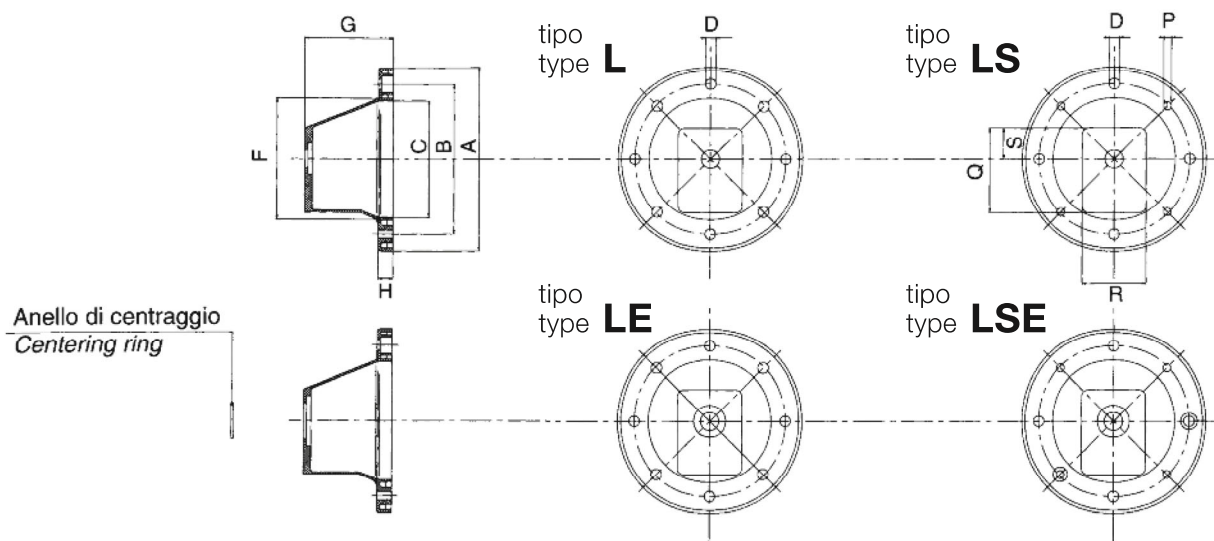

- L** 8 fori passanti lato motore
8 passing holes on motor side
- LS** 4 fori passanti + 4 fori filettati lato motore
4 passing holes + 4 threaded holes on motor side

- LE** 8 fori passanti lato motore e anello di centraggio in lamiera per estrazione del giunto
8 passing holes on motor side + sheet metal centering ring for the extraction of the coupling.
- LSE** 4 fori passanti + 4 fori filettati lato motore e anello di centraggio in lamiera per estrazione del giunto
4 passing holes + 4 threaded holes on motor side + sheet metal centering ring for the extraction of the coupling.

Tabella / Table 20

Potenza motore 4 poli 1450 giri/1' Motor power 4 poles 1450 revs/min			Semigiunto lato motore Motor side halfcoupling						
kW	Taglia Size	HP	Codice Part number	Dimensioni / Dimensions (mm)					
				A	C	G	D	CH	T
0,12	63	0,16	ND 48A	48	30	19	11	4	12,8
0,18		0,25							
0,25		0,35							
0,37	71	0,55	ND 48B	48	30	29	14	5	16,3
0,55		0,75							
0,75		1							
1,1	90	1,5	ND 48C	48	38	54	19	6	21,8
1,5		2							
0,55		0,75							
0,75	80	1	ND 48D	48	38	54	24	8	27,3
1,1		1,5							
1,5		2							
0,55	80	0,75	ND 65A	65	42	47,5	19	6	21,8
0,75		1							
1,1		1,5							
1,1	90	1,5	ND 65B	65	48	47,5	24	8	27,3
1,5		2							
2,2		3							
2,2	100	3	ND 65C	65	53	57,5	28	8	31,3
4		5,5							
2,2		3							
4	112	5,5	ND 86A	86	55	60	28	8	31,3
5,5		7,5							
5,5		12,5							
5,5	132	7,5	ND 86B	86	73	88	38	10	41,3
9		12,5							
5,5		7,5							
5,5	132	7,5	ND 108A	108	73	77	38	10	41,3
9		12,5							
11		15							
11	160	15	ND 108B	108	84	110	42	12	45,3
15		20							
18,5		25							
18,5	180	25	ND 108C	108	100	110	48	14	51,8
22		30							
30		40							
30	200	40	ND 108D	108	100	110	55	16	59,3
30		40							
30		40							
30	200	40	ND 143B	143	106	110	55	16	59,3
37		50							
45		60							
37	225	50	ND 143C	143	137	140	60	18	64,4
45		60							
45		60							



Tabella / Table 21

Rif. pompa Pump code	Dimensioni (mm) lato pompa / Dimensions (mm) pump side				
	Tipo / Type	d	Ch	t	L
05 M	cilindrico / cylindrical	6	2	7	10
05 GT	cilindrico / cylindrical	7	2	8	10
1 C	cilindrico / cylindrical	12	3	13,3	13,5
U1P	con 1:8 / taper 1:8	9,7	2,4	10,5	15
1M	con 1:8 / taper 1:8	13,9	3	15,5	18,5
2 (CA)	con 1:8 / taper 1:8	17,2	3,2	18,5	23
2 (U)	con 1:8 / taper 1:8	17,2	4	18,5	23
3U	con 1:8 / taper 1:8	22,2	4	23,6	28
35 (U)	con 1:8 / taper 1:8	25,6	4,76	27,8	35
35 (M)	con 1:8 / taper 1:8	25,6	5	27,8	35
4 (U)	con 1:8 / taper 1:8	33,3	6,35	35,5	45
4 (M/T)	con 1:8 / taper 1:8	33,3	7	35,5	45
ZB	con 1:5 / taper 1:5	9,8	2	10,2	12
ZF	con 1:5 / taper 1:5	16,9	3	17,7	19
ZG	con 1:5 / taper 1:5	25,2	5	26,3	29

GIUNTI IN ALLUMINIO ALUMINIUM COUPLINGS

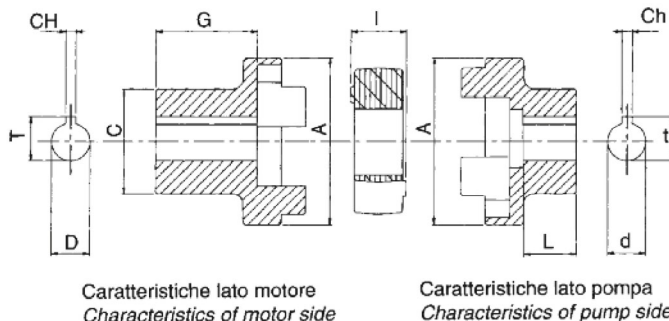

MOTORI FLANGIA B3-B5 / MOTORS WITH FLANGE B3-B5

kW	Taglia Size	HP	Motore 4 poli 1450 giri/1' Motor power 4 p. 1450 revs/min	Rif. pompa Pump code	Lanterna Bellhousing				Dimensione lanterna (mm) Dimensions of bellhousing (mm)								Giunto completo serie ND Complete coupling ND series		Semigiunto motore Halfcoupling motor side	Inserto elastico Rubber spider	Semigiunto pompa Halfcoupling pump side	Anelli di centraggio Centering ring	Piedino Foot flange	Anello Amm. Suitable damping ring									
					LE	LSE	L	LS	A	B	C	D	F	G	H	P	Q	R	S	Codice Part number	H				Codice Part number	Codice Part number	I	Codice Part number					
0,12 ÷ 0,18	63	0,16 ÷ 0,25	05 M	-	-	1401	140	140	140	115	95	10	100	60	11	M8	90	69	34	ND 01	54	ND 48A	R-42	16	ND 48P05M	-	-	-	-	-	-		
			05 GT	-	-	1401	140	140	140	115	95	10	100	60	11	M8	90	69	34	ND 02	54	ND 48A	R-42	16	ND 48P05GT	-	-	-	-	-	-		
			U 1 P	1402	141	1402	141	140	115	95	10	100	60	11	M8	90	69	34	ND 03	52	ND 48A	R-42	16	ND 48PU1P	RC1-254	-	-	-	-	-	-		
			1 C	1403	142	1403	142	140	115	95	10	100	60	11	M8	90	69	34	ND 04	52	ND 48A	R-42	16	ND 48P1C	RC1-30	-	-	-	-	-	-		
			1 M	1403	142	1403	142	140	115	95	10	100	60	11	M8	90	69	34	ND 05	52	ND 48A	R-42	16	ND 48P1M	RC1-30	-	-	-	-	-	-		
			ZB	-	-	LB18	LBS18	140	115	95	10	100	60	11	M8	90	69	34	ND 198	52	ND 48A	R-42	16	ND 48PZB	-	-	-	-	-	-	-	-	
0,25 ÷ 0,37	71	0,35 ÷ 0,55	05 M	-	-	1601	160	160	160	130	110	10	110	70	14	M8	90	69	34	ND 1	64	ND 48B	R-42	16	ND 48P05M	-	-	-	-	-	-		
			05 GT	-	-	1601	160	160	160	130	110	10	110	70	14	M8	90	69	34	ND 1A	64	ND 48B	R-42	16	ND 48P05GT	-	-	-	-	-	-		
			U 1 P	1602	161	1602	161	160	130	110	10	110	70	14	M8	90	69	34	ND 2	62	ND 48B	R-42	16	ND 48PU1P	RC1-254	-	-	-	-	-	-		
			1 C	1603	162	1603	162	160	130	110	10	110	70	14	M8	90	69	34	ND 3	62	ND 48B	R-42	16	ND 48P1C	RC1-30	-	-	-	-	-	-		
			1 M	1603	162	1603	162	160	130	110	10	110	70	14	M8	90	69	34	ND 3A	62	ND 48B	R-42	16	ND 48P1M	RC1-30	-	-	-	-	-	-		
			ZB	-	-	LB19	LBS19	160	130	110	10	110	70	14	M8	90	69	34	ND 199	62	ND 48B	R-42	16	ND 48PZB	-	-	-	-	-	-	-		
0,55 ÷ 0,75	80	0,75 ÷ 1	05 M	-	-	2101	210	200	165	130	12	135	87	15	M10	90	69	34	ND 4B	81	ND 48CG45	R-42	16	ND 48P05M	-	-	-	-	-	-			
			05 GT	-	-	2101	210	200	165	130	12	135	87	15	M10	90	69	34	ND 4C	81	ND 48CG45	R-42	16	ND 48P05GT	-	-	-	-	-	-			
			U 1 P	2102	211	2102	211	200	165	130	12	135	87	15	M10	90	69	34	ND 5A	78	ND 48CG45	R-42	16	ND 48PU1P	RC1-254	-	-	-	-	-	-		
			1 C	2103	212	2103	212	200	165	130	12	135	87	15	M10	90	69	34	ND 6B	78	ND 48CG45	R-42	16	ND 48P1C	RC1-30	-	-	-	-	-	-		
			1 M	2103	212	2103	212	200	165	130	12	135	87	15	M10	90	69	34	ND 6C	78	ND 48CG45	R-42	16	ND 48P1M	RC1-30	-	-	-	-	-	-		
			ZB	-	-	LB28	LBS28	200	165	130	12	135	87	15	M10	90	69	34	ND 300	78	ND 48CG45	R-42	16	ND 48PZB	-	-	-	-	-	-			
			05 M	-	-	2001	200	200	165	130	12	135	95	15	M10	90	69	34	ND 4	89	ND 48C	R-42	16	ND 48P05M	-	-	-	-	-	-			
			05 GT	-	-	2001	200	200	165	130	12	135	95	15	M10	90	69	34	ND 4A	89	ND 48C	R-42	16	ND 48P05GT	-	-	-	-	-	-			
			U 1 P	2002	201	2002	201	200	165	130	12	135	95	15	M10	90	69	34	ND 5	87	ND 48C	R-42	16	ND 48PU1P	RC1-254	-	-	-	-	-	-		
			1 C	2003	202	2003	202	200	165	130	12	135	95	15	M10	90	69	34	ND 6	87	ND 48C	R-42	16	ND 48P1C	RC1-30	-	-	-	-	-	-		
			1 M	2003	202	2003	202	200	165	130	12	135	95	15	M10	90	69	34	ND 6A	87	ND 48C	R-42	16	ND 48P1M	RC1-30	-	-	-	-	-	-		
			ZB	-	-	LB20	LBS20	200	165	130	12	135	95	15	M10	90	69	34	ND 200	87	ND 48C	R-42	16	ND 48PZB	-	-	-	-	-	-			
			2	2004	203	2004	203	200	165	130	12	135	95	15	M10	118	86	43	ND 7	87	ND 65A	R-62	18	ND 65P2	RC1-365	-	-	-	-	-			
			ZF	-	-	LB21	LBS21	200	165	130	12	135	95	15	M10	118	86	43	ND 202	87	ND 65A	R-62	18	ND 65P2	RC1-365	-	-	-	-	-			
			T 250	2005	205	-	-	200	165	130	12	135	126	16	M10	180	158	65	ND 50A	116	ND 86HD20	R-82	20	ND 65P2F	RC2-508	-	-	-	-	-			
			3 U	2006	206	-	-	200	165	130	12	135	126	16	M10	180	158	65	ND 50A	116	ND 86HD20	R-82	20	ND 86H3U	RC2-508	-	-	-	-	-			
			M 3	2007	207	-	-	200	165	130	12	135	126	16	M10	180	158	65	ND 50A	116	ND 86HD20	R-82	20	ND 86H3U	RC2-508	-	-	-	-	-			
			T 3	2008	208	-	-	200	165	130	12	135	126	16	M10	180	158	65	ND 50A	116	ND 86HD20	R-82	20	ND 86H3U	RC2-508	-	-	-	-	-			
			35 M	2009	209	-	-	200	165	130	12	135	126	16	M10	180	158	65	ND 50B	116	ND 86HD20	R-82	20	ND 86H35	RC2-603	-	-	-	-	-			
			35 G	2010	213	-	-	200	165	130	12	135	126	16	M10	180	158	65	ND 50B	116	ND 86HD20	R-82	20	ND 86H35	RC2-603	-	-	-	-	-			
			35 U	2010	213	-	-	200	165	130	12	135	126	16	M10	180	158	65	ND 50B	116	ND 86HD20	R-82	20	ND 86H35	RC2-603	-	-	-	-	-			
			ZG	-	-	2011	214	200	165	130	12	135	126	16	M10	180	158	65	ND 50D	116	ND 86HD20	R-82	20	ND 86HZG	-	-	-	-	-	-			
			1,1 ÷ 1,5	90	1,5 ÷ 2	U 1 P	2002	201	2002	201	200	165	130	12	135	95	15	M10	90	69	34	ND 70A	87	ND 48D	R-42	16	ND 48PU1P	RC1-254	-	-	-	-	-
						1 C	2003	202	2003	202	200	165	130	12	135	95	15	M10	90	69	34	ND 70B	87	ND 48D	R-42	16	ND 48P1C	RC1-30	-	-	-	-	-
1 M	2003	202				2003	202	200	165	130	12	135	95	15	M10	90	69	34	ND 70C	87	ND 48D	R-42	16	ND 48P1M	RC1-30	-	-	-	-	-			
ZB	-	-				LB20	LBS20	200	165	130	12	135	95	15	M10	90	69	34	ND 70D	87	ND 48D	R-42	16	ND 48PZB	-	-	-	-	-				
U 1 P	2002	201				2002	201	200	165	130	12	135	95	15	M10	90	69	34	ND 8	87	ND 65B	R-62	18	ND 65PU1P	RC1-254	-	-	-	-	-			
1 C	2003	202				2003	202	200	165	130	12	135	95	15	M10	90	69	34	ND 9	87	ND 65B	R-62	18	ND 65P1C	RC1-30	-	-	-	-	-			
1 M	2003	202				2003	202	200	165	130	12	135	95	15	M10	90	69	34	ND 9A	87	ND 65B	R-62	18	ND 65P1M	RC1-30	-	-	-	-	-			
ZB	-	-				LB20	LBS20	200	165	130	12	135	95	15	M10	90	69	34	ND 201	87	ND 65B	R-62	18	ND 65PZB	-	-	-	-	-				
2	2004	203				2004	203	200	165	130	12	135	95	15	M10	118	86	43	ND 10	87	ND 65B	R-62	18	ND 65P2	RC1-365	-	-	-	-				
ZF	-	-				LB21	LBS21	200	165	130	12	135	95	15	M10	118	86	43	ND 203	87	ND 65B	R-62	18	ND 65P2F	RC1-365	-	-	-	-				
T 250	2005	205				-	-	200	165	130	12	135	126	16	M10	180	158	65	ND 51A	116	ND 86HD31	R-82	20	ND 86H3U	RC2-508	-	-	-	-	-			
3 U	2006	206				-	-	200	165	130	12	135	126	16	M10	180	158	65	ND 51A	116	ND 86HD31	R-82	20	ND 86H3U	RC2-508	-	-	-	-	-			
M 3	2007	207				-	-	200	165	130	12	135	126	16	M10	180	158	65	ND 51A	116	ND 86HD31	R-82	20	ND 86H3U	RC2-508	-	-	-	-	-			
T 3	2008	208				-	-	200	165	130																							

GIUNTI IN ACCIAIO STEEL COUPLINGS



MOTORI FLANGIA B3-B5 / MOTORS WITH FLANGE B3-B5

kW	Taglia Size	HP	Motore 4 poli 1450 giri/1' Motor power 4 p. 1450 revs/min	Rif. pompa Pump code	Lanterna Bellhousing				Dimensione lanterna (mm) Dimensions of bellhousing (mm)										Giunto completo serie ND Complete coupling ND series		Semigiunto Pompa Halfcoupling pump side		Inserto elastico Rubber spider		Semigiunto pompa Halfcoupling pump side		Piedino Foot flange	Anello Amm. Suitable damping ring
					LE	LSE	L	LS	A	B	C	D	F	G	H	P	Q	R	S	Codice Part number	H	Codice Part number	H	Codice Part number	I	Codice Part number		
0,12 ± 0,18	63	0,16 ± 0,25	05 M	-	-	1401	140	140	140	140	115	95	10	100	60	11	M8	90	69	34	AGN 01	50	OMT 1023C02	POL-1	4	OMT 1023M05	P - 160	
			05 GT	-	-	1401	140	140	140	140	115	95	10	100	60	11	M8	90	69	34	AGN 02	50	OMT 1023C02	POL-1	4	OMT 1023G05		
			U 1 P	1402	141	1402	141	140	115	95	10	100	60	11	M8	90	69	34	AGN 03	50	OMT 1023C02	POL-1	4	OMT 1023U1P				
			1 C	1403	142	1403	142	140	115	95	10	100	60	11	M8	90	69	34	AGN 04	50	OMT 1023C02	POL-1	4	OMT 1023C1				
			1 M	1403	142	1403	142	140	115	95	10	100	60	11	M8	90	69	34	AGN 05	50	OMT 1023C02	POL-1	4	OMT 1023M1				
			ZB	-	-	LB18	LBS18	140	115	95	10	100	60	11	M8	90	69	34	AGN 198	50	OMT 1023C02	POL-1	4	OMT 1023ZB				
			05 M	-	-	1601	160	160	160	160	130	110	10	110	70	14	M8	90	69	34	AGN 1	57	OMT 1030C07	POL-1	4	OMT 1023M05		
05 GT	-	-	1601	160	160	160	160	130	110	10	110	70	14	M8	90	69	34	AGN 1A	57	OMT 1030C07	POL-1	4	OMT 1023G05					
U 1 P	1602	161	1602	161	160	130	110	10	110	70	14	M8	90	69	34	AGN 2	57	OMT 1030C07	POL-1	4	OMT 1023U1P							
1 C	1603	162	1603	162	160	130	110	10	110	70	14	M8	90	69	34	AGN 3	57	OMT 1030C07	POL-1	4	OMT 1023C1							
1 M	1603	162	1603	162	160	130	110	10	110	70	14	M8	90	69	34	AGN 3A	57	OMT 1030C07	POL-1	4	OMT 1023M1							
ZB	-	-	LB19	LBS19	160	130	110	10	110	70	14	M8	90	69	34	AGN 199	57	OMT 1030C07	POL-1	4	OMT 1023ZB							
0,55 ± 0,75	80	0,75 ± 1	05 M	-	-	2101	210	200	165	130	12	135	87	15	M10	90	69	34	AGN 4	70	OMT 2033C20	POL-2	4	OMT 2033M05	P - 200	A - 200		
			05 GT	-	-	2101	210	200	165	130	12	135	87	15	M10	90	69	34	AGN 4A	70	OMT 2033C20	POL-2	4	OMT 2033G05				
			U 1 P	2102	211	2102	211	200	165	130	12	135	87	15	M10	90	69	34	AGN 5	70	OMT 2033C20	POL-2	4	OMT 2033U1P				
			1 C	2103	212	2103	212	200	165	130	12	135	87	15	M10	90	69	34	AGN 6	70	OMT 2033C20	POL-2	4	OMT 2033C1				
			1 M	2103	212	2103	212	200	165	130	12	135	87	15	M10	90	69	34	AGN 6A	70	OMT 2033C20	POL-2	4	OMT 2033M1				
			ZB	-	-	LB28	LBS28	200	165	130	12	135	87	15	M10	90	69	34	AGN 200	70	OMT 2033C20	POL-2	4	OMT 2033ZB				
			05 M	-	-	2001	200	200	165	130	12	135	95	15	M10	90	69	34	AGN 4	70	OMT 2033C20	POL-2	4	OMT 2033M05				
			05 GT	-	-	2001	200	200	165	130	12	135	95	15	M10	90	69	34	AGN 4A	70	OMT 2033C20	POL-2	4	OMT 2033G05				
			U 1 P	2002	201	2002	201	200	165	130	12	135	95	15	M10	90	69	34	AGN 5	70	OMT 2033C20	POL-2	4	OMT 2033U1P				
			1 C	2003	202	2003	202	200	165	130	12	135	95	15	M10	90	69	34	AGN 6	70	OMT 2033C20	POL-2	4	OMT 2033C1				
			1 M	2003	202	2003	202	200	165	130	12	135	95	15	M10	90	69	34	AGN 6A	70	OMT 2033C20	POL-2	4	OMT 2033M1				
			ZB	-	-	LB20	LBS20	200	165	130	12	135	95	15	M10	90	69	34	AGN 200	70	OMT 2033C20	POL-2	4	OMT 2033ZB				
			2 CA	2004	203	2004	203	200	165	130	12	135	95	15	M10	118	86	43	AGN 7	70	OMT 2033C20	POL-2	4	OMT 2033CA2				
			2 U	2004	203	2004	203	200	165	130	12	135	95	15	M10	118	86	43	AGN 7A	70	OMT 2033C20	POL-2	4	OMT 2033U2				
			ZF	-	-	LB21	LBS21	200	165	130	12	135	95	15	M10	118	86	43	AGN 202	70	OMT 2033C20	POL-2	4	OMT 2033ZF				
			U 1 P	2002	201	2002	201	200	165	130	12	135	95	15	M10	90	69	34	AGN 8	70	OMT 2033C31	POL-2	4	OMT 2033U1P				
			1 C	2003	202	2003	202	200	165	130	12	135	95	15	M10	90	69	34	AGN 9	70	OMT 2033C31	POL-2	4	OMT 2033C1				
1 M	2003	202	2003	202	200	165	130	12	135	95	15	M10	90	69	34	AGN 9A	70	OMT 2033C31	POL-2	4	OMT 2033M1							
ZB	-	-	LB20	LBS20	200	165	130	12	135	95	15	M10	90	69	34	AGN 201	70	OMT 2033C31	POL-2	4	OMT 2033ZB							
U 1 P	2002	201	2002	201	200	165	130	12	135	95	15	M10	90	69	34	AGN 8	70	OMT 2033C31	POL-2	4	OMT 2033U1P							
1 C	2003	202	2003	202	200	165	130	12	135	95	15	M10	90	69	34	AGN 9	70	OMT 2033C31	POL-2	4	OMT 2033C1							
1 M	2003	202	2003	202	200	165	130	12	135	95	15	M10	90	69	34	AGN 9A	70	OMT 2033C31	POL-2	4	OMT 2033M1							
ZB	-	-	LB20	LBS20	200	165	130	12	135	95	15	M10	90	69	34	AGN 201	70	OMT 2033C31	POL-2	4	OMT 2033ZB							
2 CA	2004	203	2004	203	200	165	130	12	135	95	15	M10	118	86	43	AGN 10	70	OMT 2033C31	POL-2	4	OMT 2033CA2							
2 U	2004	203	2004	203	200	165	130	12	135	95	15	M10	118	86	43	AGN 10A	70	OMT 2033C31	POL-2	4	OMT 2033U2							
ZF	-	-	LB21	LBS21	200	165	130	12	135	95	15	M10	118	86	43	AGN 203	70	OMT 2033C31	POL-2	4	OMT 2033ZF							
2 CA	2004	203	2004	203	200	165	130	12	135	95	15	M10	118	86	43	AGN 10	70	OMT 2033C31	POL-2	4	OMT 2033CA2							
2 U	2004	203	2004	203	200	165	130	12	135	95	15	M10	118	86	43	AGN 10A	70	OMT 2033C31	POL-2	4	OMT 2033U2							
ZF	-	-	LB21	LBS21	200	165	130	12	135	95	15	M10	118	86	43	AGN 203	70	OMT 2033C31	POL-2	4	OMT 2033ZF							
2,2 ± 4	100 ± 112	3 ± 5,5	U 1 P	2501	250	2501	250	250	215	180	14	185	105	21	M12	118	86	43	AGN 11	74	OMT 3040C36	POL-3	4	OMT 3030U1P	P - 250	A - 250		
			1 C	2502	251	2502	251	250	215	180	14	185	105	21	M12	118	86	43	AGN 12	74	OMT 3040C36	POL-3	4	OMT 3030C1				
			1 M	2502	251	2502	251	250	215	180	14	185	105	21	M12	118	86	43	AGN 12A	74	OMT 3040C36	POL-3	4	OMT 3030M1				
			2 CA	2503	252	2503	252	250	215	180	14	185	105	21	M12	118	86	43	AGN 12B	74	OMT 3040C36	POL-3	4	OMT 3030CA2				
			2 U	2503	252	2503	252	250	215	180	14	185	105	21	M12	118	86	43	AGN 12C	74	OMT 3040C36	POL-3	4	OMT 3030U2				
			ZB	-	-	LB22	LBS22	250	215	180	14	185	105	21	M12	118	86	43	AGN 204	74	OMT 3040C36	POL-3	4	OMT 3030ZB				
			ZF	-	-	LB23	LBS23	250	215	180	14	185	105	21	M12	118	86	43	AGN 205	74	OMT 3040C36	POL-3	4	OMT 3030ZF				
			2 CA	2504	253	2504	253	250	215	180	14	185	115	21	M12	170	120	59	AGN 13	84	OMT 3040C36	POL-3	4	OMT 3040CA2				
			2 U	2504	253	2504	253	250	215	180	14	185	115	21	M12	170	120	59	AGN 13A	84	OMT 3040C36	POL-3	4	OMT 3040U2				
			T 250	2505	254	2505	254	250	215	180	14	185	115	21	M12	170	120	59	AGN 14	84	OMT 3040C36	POL-3	4	OMT 3040U3				
			3 U	2506	255	2506	255	250	215	180	14	185	115	21	M12	170	120	59	AGN 14	84	OMT 3040C36	POL-3	4	OMT 3040U3				
			M 3	2507	256	2507	256	250	215	180	14	185	115	21	M12	170	120	59	AGN 14	84	OMT 3040C36	POL-3	4	OMT 3040U3				
			T 3	2508	257	2508	257	250	215	180	14	185	115	21	M12	170	120	59	AGN 14	84	OMT 3040C36	POL-3	4	OMT 3040U3				
			ZF	-	-	LB24	LBS24	250	215	180	14	185	115	21	M12	170	120	59	AG									

GIUNTI IN ACCIAIO STEEL COUPLINGS



MOTORI FLANGIA B3-B5 / MOTORS WITH FLANGE B3-B5

kW	Taglia Size	HP	Motore 4 poli 1450 giri/1' Motor power 4 p. 1450 revs/min	Rif. pompa Pump code	Lanterna Bellhousing				Dimensione lanterna (mm) Dimensions of bellhousing (mm)								Giunto completo serie ND Complete coupling ND series		Semigiunto Motore Halfcoupling motor side		Inserto elastico Rubber spider		Semigiunto pompa Halfcoupling pump side		Piedino Foot flange	Anello Amm. Suitable damping ring
					LE	LSE	L	LS	A	B	C	D	F	G	H	P	Q	R	S	Codice Part number	H	Codice Part number	Codice Part num.	I		
5,5 ÷ 9	132	7,5 ÷ 12,5	2 CA	3001	300	3001	300	300	265	230	14	235	143	21	M12	170	120	59	AGN 15	104	OMT 4050C47	POL-4	4	OMT 4050CA2	P-300	A-300
			2 U	3001	300	3001	300	300	265	230	14	235	143	21	M12	170	120	59	AGN 15A	104	OMT 4050C47	POL-4	4	OMT 4050U2		
			T 250	3002	301	3002	301	300	265	230	14	235	143	21	M12	170	120	59	AGN 16	104	OMT 4050C47	POL-4	4	OMT 4050U3		
			3 U	3003	302	3003	302	300	265	230	14	235	143	21	M12	170	120	59	AGN 16	104	OMT 4050C47	POL-4	4	OMT 4050U3		
			M 3	3004	303	3004	303	300	265	230	14	235	143	21	M12	170	120	59	AGN 16	104	OMT 4050C47	POL-4	4	OMT 4050U3		
			T 3	3005	304	3005	304	300	265	230	14	235	143	21	M12	170	120	59	AGN 16	104	OMT 4050C47	POL-4	4	OMT 4050U3		
			ZF	-	-	LB26	LBS26	300	265	230	14	235	143	21	M12	170	120	59	AGN 208	104	OMT 4050C47	POL-4	4	OMT 4050ZF		
			ZG	-	-	LB27	LBS27	300	265	230	14	235	143	21	M12	170	120	59	AGN 209	104	OMT 4050C47	POL-4	4	OMT 4050ZG		
			35 M	3006	305	3006	305	300	265	230	14	235	143	21	M12	180	158	62	AGN 17	104	OMT 4050C47	POL-4	4	OMT 4050G35		
			35 G	3007	306	3007	306	300	265	230	14	235	143	21	M12	180	158	62	AGN 17	104	OMT 4050C47	POL-4	4	OMT 4050G35		
			35 U	3007	306	3007	306	300	265	230	14	235	143	21	M12	180	158	62	AGN 18	104	OMT 4050C47	POL-4	4	OMT 4050U35		
			11 ÷ 15	160	15 ÷ 20	2 CA	-	-	3511	350	350	300	250	18	253	178	25	M16	230	175	77	AGN 19	124	OMT 5060C51		
2 U	-	-				3511	350	350	300	250	18	253	178	25	M16	230	175	77	AGN 19A	124	OMT 5060C51	POL-5	4	OMT 5060U2		
T 250	3512	351				3512	351	350	300	250	18	253	178	25	M16	230	175	77	AGN 20	124	OMT 5060C51	POL-5	4	OMT 5060U3		
3 U	3513	352				3513	352	350	300	250	18	253	178	25	M16	230	175	77	AGN 20	124	OMT 5060C51	POL-5	4	OMT 5060U3		
M 3	3514	353				3514	353	350	300	250	18	253	178	25	M16	230	175	77	AGN 20	124	OMT 5060C51	POL-5	4	OMT 5060U3		
T 3	3515	354				3515	354	350	300	250	18	253	178	25	M16	230	175	77	AGN 20	124	OMT 5060C51	POL-5	4	OMT 5060U3		
ZF	-	-				LB31	LBS31	350	300	250	18	253	178	25	M16	230	175	77	AGN 210	124	OMT 5060C51	POL-5	4	OMT 5060ZF		
ZG	-	-				LB32	LBS32	350	300	250	18	253	178	25	M16	230	175	77	AGN 212	124	OMT 5060C51	POL-5	4	OMT 5060ZG		
35 M	3506	355				-	-	350	300	250	18	253	188	25	M16	230	175	77	AGN 21	124	OMT 5060C51	POL-5	4	OMT 5060G35		
35 G	3507	356				-	-	350	300	250	18	253	188	25	M16	230	175	77	AGN 21	124	OMT 5060C51	POL-5	4	OMT 5060G35		
35 U	3507	356				-	-	350	300	250	18	253	188	25	M16	230	175	77	AGN 22	124	OMT 5060C51	POL-5	4	OMT 5060U35		
4 M	3508	357				-	-	350	300	250	18	253	188	25	M16	230	175	77	AGN 23	124	OMT 5060C51	POL-5	4	OMT 5060M4		
4 T	3508	357	-	-	350	300	250	18	253	188	25	M16	230	175	77	AGN 23	124	OMT 5060C51	POL-5	4	OMT 5060M4					
4 U	3509	358	-	-	350	300	250	18	253	188	25	M16	230	175	77	AGN 24	124	OMT 5060C51	POL-5	4	OMT 5060U4					
18,5 ÷ 22	180	25 ÷ 30	2 CA	-	-	3511	350	350	300	250	18	253	178	25	M16	230	175	77	AGN 25	124	OMT 5060C54	POL-5	4	OMT 5060CA2	P-350	A-350
			2 U	-	-	3511	350	350	300	250	18	253	178	25	M16	230	175	77	AGN 25A	124	OMT 5060C54	POL-5	4	OMT 5060U2		
			T 250	3512	351	3512	351	350	300	250	18	253	178	25	M16	230	175	77	AGN 26	124	OMT 5060C54	POL-5	4	OMT 5060U3		
			3 U	3513	352	3513	352	350	300	250	18	253	178	25	M16	230	175	77	AGN 26	124	OMT 5060C54	POL-5	4	OMT 5060U3		
			M 3	3514	353	3514	353	350	300	250	18	253	178	25	M16	230	175	77	AGN 26	124	OMT 5060C54	POL-5	4	OMT 5060U3		
			T 3	3515	354	3515	354	350	300	250	18	253	178	25	M16	230	175	77	AGN 26	124	OMT 5060C54	POL-5	4	OMT 5060U3		
			ZF	-	-	LB31	LBS31	350	300	250	18	253	178	25	M16	230	175	77	AGN 211	124	OMT 5060C54	POL-5	4	OMT 5060ZF		
			ZG	-	-	LB32	LBS32	350	300	250	18	253	178	25	M16	230	175	77	AGN 213	124	OMT 5060C54	POL-5	4	OMT 5060ZG		
			35 M	3506	355	-	-	350	300	250	18	253	188	25	M16	230	175	77	AGN 27	124	OMT 5060C54	POL-5	4	OMT 5060G35		
			35 G	3507	356	-	-	350	300	250	18	253	188	25	M16	230	175	77	AGN 27	124	OMT 5060C54	POL-5	4	OMT 5060G35		
			35 U	3507	356	-	-	350	300	250	18	253	188	25	M16	230	175	77	AGN 28	124	OMT 5060C54	POL-5	4	OMT 5060U35		
			4 M	3508	357	-	-	350	300	250	18	253	188	25	M16	230	175	77	AGN 29	124	OMT 5060C54	POL-5	4	OMT 5060M4		
4 T	3508	357	-	-	350	300	250	18	253	188	25	M16	230	175	77	AGN 29	124	OMT 5060C54	POL-5	4	OMT 5060M4					
4 U	3509	358	-	-	350	300	250	18	253	188	25	M16	230	175	77	AGN 30	124	OMT 5060C54	POL-5	4	OMT 5060U4					
30	200	40	T 250	4001	400	-	-	400	350	300	18	299	188	25	M16	272	247	123	AGN 31	150,5	OMT 6080C56	POL-6	8	OMT 6062U3	A-400	
			3 U	4002	401	-	-	400	350	300	18	299	188	25	M16	272	247	123	AGN 31	150,5	OMT 6080C56	POL-6	8	OMT 6062U3		
			M 3	4003	402	-	-	400	350	300	18	299	188	25	M16	272	247	123	AGN 31	150,5	OMT 6080C56	POL-6	8	OMT 6062U3		
			T 3	4004	403	-	-	400	350	300	18	299	188	25	M16	272	247	123	AGN 31	150,5	OMT 6080C56	POL-6	8	OMT 6062U3		
			35 M	4005	404	-	-	400	350	300	18	299	188	25	M16	272	247	123	AGN 32	150,5	OMT 6080C56	POL-6	8	OMT 6062G35		
			35 G	4006	405	-	-	400	350	300	18	299	188	25	M16	272	247	123	AGN 32	150,5	OMT 6080C56	POL-6	8	OMT 6062G35		
			35 U	4006	405	-	-	400	350	300	18	299	188	25	M16	272	247	123	AGN 32A	150,5	OMT 6080C56	POL-6	8	OMT 6062U35		
			4 M	4007	406	-	-	400	350	300	18	299	188	25	M16	272	247	123	AGN 33	150,5	OMT 6080C56	POL-6	8	OMT 6062M4		
			4 T	4007	406	-	-	400	350	300	18	299	188	25	M16	272	247	123	AGN 33	150,5	OMT 6080C56	POL-6	8	OMT 6062M4		
			4 U	4008	407	-	-	400	350	300	18	299	188	25	M16	272	247	123	AGN 33A	150,5	OMT 6080C56	POL-6	8	OMT 6062U4		
			ZG	-	-	LB30	LBS30	400	350	300	18	299	188	25	M16	272	247	123	AGN 214	150,5	OMT 6080C56	POL-6	8	OMT 6062ZG		
			37 ÷ 45	225	50 ÷ 60	35 M	-	-	4501*	450*	450	400	350	18	350	218	25	M16	287,5	175	137,5	AGN 34	150,5	OMT 6080C57		
35 G	-	-				4502*	451*	450	400	350	18	350	218	25	M16	287,5	175	137,5	AGN 34	150,5	OMT 6080C57	POL-6	8	OMT 6062G35		
35 U	-	-				4502*	451*	450	400	350	18	350	218	25	M16	287,5	175	137,5	AGN 34A	150,5	OMT 6080C57	POL-6	8	OMT 6062U35		
4 M	-	-				4503*	452*	450	400	350	18	350	218	25	M16	287,5	175	137,5								

MOTORI FLANGIA B14 / MOTORS WITH FLANGE B14

Motore 4 poli 1450 giri/1' Motor power 4 p. 1450 revs/min			Rif. pompa Pump code	Lanterna Bellhousing		Dimensione lanterna (mm) Dimensions of bellhousing (mm)										Giunto completo serie ND Complete coupling ND series		Semigiunto Motore Halfcoupling motor side		Inserto elastico Rubber spider		Semigiunto pompa Halfcoupling pump side		Piedino Foot flange Anello amm. Damping ring
kW	Taglia Size	HP		L	LS	A	B	C	D	F	G	H	P	Q	R	S	Codice Part number	H	Codice Part number	Codice Part num.	I	Codice Part number		
0,12 ± 0,18	63	0,16 ± 0,25	0,5M	901	-	90	75	60	6,5	62	60	10	-	90	69	34	ND 01	54	ND 48A	R-42	16	ND 48P05M		
			0,5GT	901	-	90	75	60	6,5	62	60	10	-	90	69	34	ND 02	54	ND 48A	R-42	16	ND 48P05GT		
			U1P	902	-	90	75	60	6,5	62	60	10	-	90	69	34	ND 03	52	ND 48A	R-42	16	ND 48PU1P		
			1C	903	-	90	75	60	6,5	62	60	10	-	90	69	34	ND 04	52	ND 48A	R-42	16	ND 48P1C		
			1M	903	-	90	75	60	6,5	62	60	10	-	90	69	34	ND 05	52	ND 48A	R-42	16	ND 48P1M		
			ZB	LB 9	-	90	75	60	6,5	62	60	10	-	90	69	34	ND 198	52	ND 48A	R-42	16	ND 48PZB		
0,25 ± 0,37	71	0,35 ± 0,55	0,5M	1051	-	105	85	70	7	70	70	10	-	90	69	34	ND 1	64	ND 48B	R-42	16	ND 48P05M		
			0,5GT	1051	-	105	85	70	7	70	70	10	-	90	69	34	ND 1A	64	ND 48B	R-42	16	ND 48P05GT		
			U1P	1052	-	105	85	70	7	70	70	10	-	90	69	34	ND 2	62	ND 48B	R-42	16	ND 48PU1P		
			1C	1053	-	105	85	70	7	70	70	10	-	90	69	34	ND 3	62	ND 48B	R-42	16	ND 48P1C		
			1M	1053	-	105	85	70	7	70	70	10	-	90	69	34	ND 3A	62	ND 48B	R-42	16	ND 48P1M		
			ZB	LB 10	-	105	85	70	7	70	70	10	-	90	69	34	ND 199	62	ND 48B	R-42	16	ND 48PZB		
0,55 ± 0,75	80	0,75 ± 1	0,5M	1201	-	120	100	80	7	80	85	12	-	120	90	45	ND 4B	80	ND 48CG45	R-42	16	ND 48P05M		
			0,5GT	1201	-	120	100	80	7	80	85	12	-	120	90	45	ND 4C	80	ND 48CG45	R-42	16	ND 48P05GT		
			U1P	1202	-	120	100	80	7	80	85	12	-	120	90	45	ND 5A	98	ND 48CG45	R-42	16	ND 48PU1P		
			1C	1203	-	120	100	80	7	80	85	12	-	120	90	45	ND 6B	78	ND 48CG45	R-62	18	ND 48P1C		
			1M	1203	-	120	100	80	7	80	85	12	-	120	90	45	ND 6C	78	ND 48CG45	R-62	18	ND 48P1M		
			ZB	LB 11	-	120	100	80	7	80	85	12	-	120	90	45	ND 300	78	ND 48CG45	R-62	18	ND 48PZB		
			2	1204	-	120	100	80	7	80	85	12	-	120	90	45	ND 7B	77,5	ND 65AG38	R-62	18	ND 65P2		
			ZF	LB 12	-	120	100	80	7	80	85	12	-	120	90	45	ND 207	77,5	ND 65AG38	R-62	18	ND 65PZF		
1,1 ± 1,5	90	1,5 ± 2	U1P	1410	149	140	115	95	9,5	100	95	12	M8	120	90	45	ND 8	87	ND 65B	R-62	18	ND 65PU1P		
			1C	1411	150	140	115	95	9,5	100	95	12	M8	120	90	45	ND 9	87	ND 65B	R-62	18	ND 65P1C		
			1M	1411	150	140	115	95	9,5	100	95	12	M8	120	90	45	ND 9A	87	ND 65B	R-62	18	ND 65P1M		
			ZB	LB 40	LBS 40	140	115	95	9,5	100	95	12	M8	120	90	45	ND 201	87	ND 65B	R-62	18	ND 65PZB		
			2	1409	148	140	115	95	9,5	100	95	12	M8	120	90	45	ND 10	87	ND 65B	R-62	18	ND 65P2		
			ZF	LB 14	LBS 14	140	115	95	9,5	100	95	12	M8	120	90	45	ND 203	87	ND 65B	R-62	18	ND 65PZF		
2,2 ± 4	100 ± 112	3 ± 5,5	U1P	1610	169	160	130	110	9,5	114	105	14	M8	120	90	45	ND 11	97	ND 65C	R-62	18	ND 65PU1P		
			1C	1611	170	160	130	110	9,5	114	105	14	M8	120	90	45	ND 12	97	ND 65C	R-62	18	ND 65P1C		
			1M	1611	170	160	130	110	9,5	114	105	14	M8	120	90	45	ND 12A	97	ND 65C	R-62	18	ND 65P1M		
			ZB	LB 17	LBS 17	160	130	110	9,5	114	105	14	M8	120	90	45	ND 204	97	ND 65C	R-62	18	ND 65PZB		
			2	1609	168	160	130	110	9,5	114	105	14	M8	120	90	45	ND 13	97	ND 65C	R-62	18	ND 65P2		
			ZF	LB 16	LBS 16	160	130	110	9,5	114	105	14	M8	120	90	45	ND 206	97	ND 65C	R-62	18	ND 65PZF		
5,5 ± 7,5	132	7,5 ± 10	2	2015	-	200	165	130	11,5	137	139	16	-	150	132	72	ND 16B	127	ND 86BG80	R-82	20	ND 86P2		
			ZF	LB 41	-	200	165	130	11,5	137	139	16	-	150	132	72	ND 311	127	ND 86BG80	R-82	20	ND 86PZF		
			T250	2016	-	200	165	130	11,5	137	139	16	-	150	132	72	ND 17A	127	ND 86BG80	R-82	20	ND 86P3U		
			3U	2017	-	200	165	130	11,5	137	139	16	-	150	132	72	ND 17A	127	ND 86BG80	R-82	20	ND 86P3U		
			M3	2018	-	200	165	130	11,5	137	139	16	-	150	132	72	ND 17A	127	ND 86BG80	R-82	20	ND 86P3U		
			T3	2019	-	200	165	130	11,5	137	139	16	-	150	132	72	ND 17A	127	ND 86BG80	R-82	20	ND 86P3U		
			ZG	LB 42	-	200	165	130	11,5	137	139	16	-	150	132	72	ND 312	127	ND 86BG80	R-82	20	ND 86PZG		